



# Post – Trip Trailer Form

**\*\*Please fill out before departure, put in drop box or turn into office.\*\***  
Thank You.

Coach Name: \_\_\_\_\_ Date: \_\_\_\_\_

Driver Name: \_\_\_\_\_ VIN #: \_\_\_\_\_

Trailer #: \_\_\_\_\_ Tour: \_\_\_\_\_

EXTERIOR	
- Wash	
- Paint	
- Body	
PIGTAIL	
- Wiring	
- Connections	
INTERIOR	
- Swept	
- Dry	
- Walls (NO DAMAGE)	
LIGHTS	
- Clearance	
- Brake	
- Turn	
- Interior	
WHEELS	
- Studs/Lugs	
- Pressure	
- Wear	
DOORS	
- Hinges	
- Handles	
DOCUMENTS	
- Copy of Registration	
- Annual DOT Inspection	

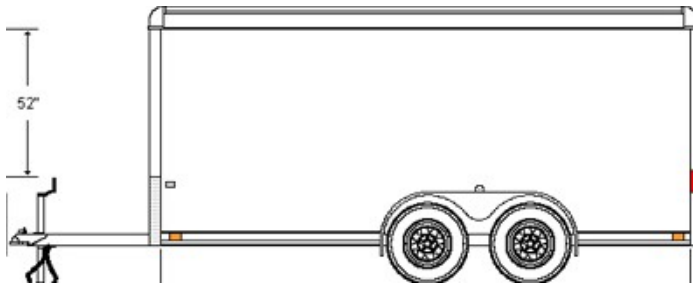
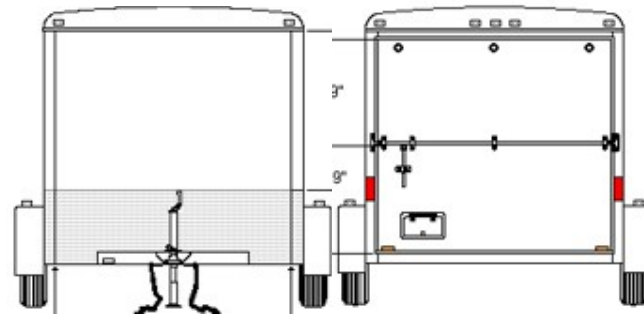
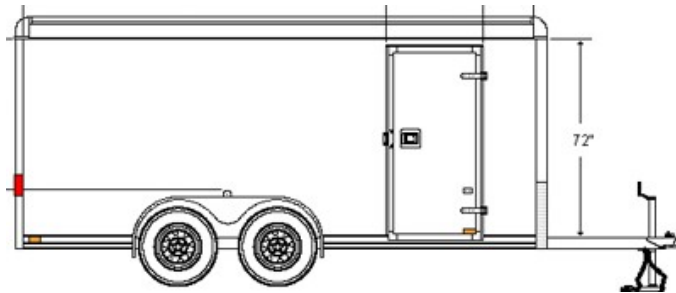

**REPAIRS IF NEEDED**

---



---



---



---



---

Drivers Signature: \_\_\_\_\_

Date: \_\_\_\_\_